

Name: _____		Date: _____		Event: _____	
City: _____		State: _____		Track: _____	
Track Conditions	<input type="checkbox"/> Indoor	<input type="checkbox"/> Tight	<input type="checkbox"/> Smooth	<input type="checkbox"/> Hard Packed	<input type="checkbox"/> Blue Groove
	<input type="checkbox"/> Outdoor	<input type="checkbox"/> Open	<input type="checkbox"/> Rough	<input type="checkbox"/> Loose/Loamy	<input type="checkbox"/> Dry
				<input type="checkbox"/> Wet	<input type="checkbox"/> Grass
				<input type="checkbox"/> Dusty	<input type="checkbox"/> Astro Turf
				<input type="checkbox"/> Low Bite	<input type="checkbox"/> High Bite
				<input type="checkbox"/> Med Bite	<input type="checkbox"/> Other _____

**Front Suspension**

Toe: \_\_\_\_\_

Ride Height: \_\_\_\_\_

Camber: \_\_\_\_\_

Caster:  0°  5°      Trail:  2mm  4mm

Kick Angle:  20°  25°  30°

Sway Bar: \_\_\_\_\_

Oil: \_\_\_\_\_

Piston: \_\_\_\_\_

Spring:  Standard  Low Freq.    Color: \_\_\_\_\_

Front Pivot:  Aluminum  Plastic  HRC

Kick Shim:  Brass  Plastic

Shock Limiters: \_\_\_\_\_

Shock Location: \_\_\_\_\_

Bump Steer Ball Stud:  Standard  Low Mount

Bumper Steer Spacers: \_\_\_\_\_

Ackermann Ball Stud:  Standard  Low Mount

Ackermann Spacers: \_\_\_\_\_

Camber Link: \_\_\_\_\_

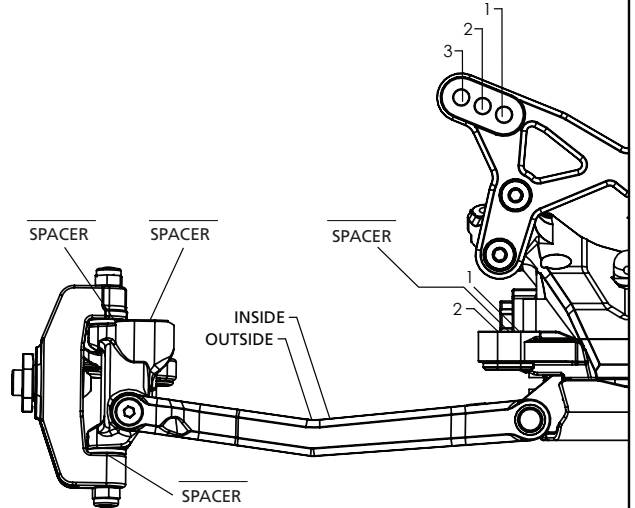

Notes: \_\_\_\_\_

\_\_\_\_\_

\_\_\_\_\_

**Rear Suspension**

Chassis Configuration:  Rear Motor  Mid Motor

Toe: \_\_\_\_\_

Anti-Squat: \_\_\_\_\_

Roll Center:  Low Roll Center (LRC)  High Roll Center (HRC)

Ride Height: \_\_\_\_\_

Camber: \_\_\_\_\_

Rear Hub Spacing: \_\_\_\_\_

Hex Width: \_\_\_\_\_

Sway Bar: \_\_\_\_\_

Oil: \_\_\_\_\_

Piston: \_\_\_\_\_

Spring:  Standard  Low Freq.    Color: \_\_\_\_\_

Shock Limiters: \_\_\_\_\_

Camber Link: \_\_\_\_\_

Shock Locations: \_\_\_\_\_

Wing/Wickerbill: \_\_\_\_\_

Battery Position: \_\_\_\_\_

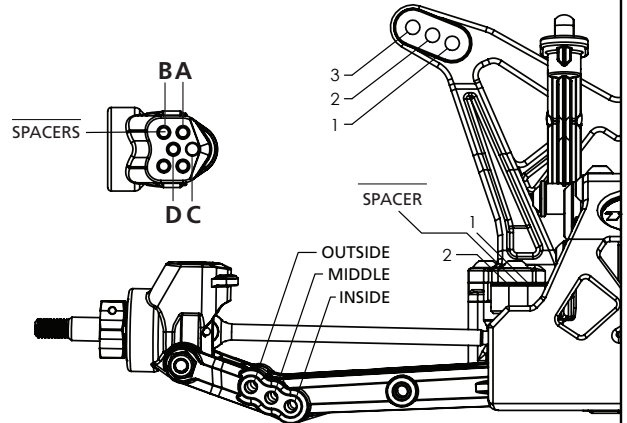

**Electronics**

Radio: _____	Timing Advance: _____
Servo: _____	Throttle/Brake Expo: _____
ESC: _____	Servo Expo: _____
Initial Brake: _____	Throttle/Brake EPA: _____
Drag Brake: _____	Motor: _____
Throttle Profile: _____	Pinion: _____ Spur: _____
	Battery: _____

**Weight Placement**  
(Mark with "X")



Weight of each piece \_\_\_\_\_ oz./g

Tires	Compound	Insert	Additive
Front: _____	_____	_____	_____
Rear: _____	_____	_____	_____
Notes: _____	_____		